

IS 16 - IS 19

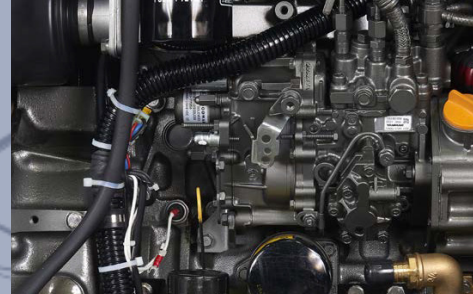

CONTROL PANEL



YANMAR ENGINE



INPUT/OUTPUT FUEL PIPE

the intercooler W/A assures the perfect functioning of the generator independently of the external ambient temperature, therefore the alternator and the engine will work at ideal temperature optimizing the performance and reliability of the gen-set.

The generator may be installed in any room on the vessel without the need of ventilation blowers.

Extremely compact and quiet, the generator is equipped with a double shock absorbing system to increase comfort: the first one absorbs vibrations from engine-alternator to the frame, the second one absorbs residual micro-vibrations from frame to vessel.



COMPACT DESIGN



EASY INSTALLATION



SUPER SILENCED



MANUFACTURERS

We reserve the right to modify the data, images and drawings in this document without prior notice.

For more detailed information, please contact your local distributor or Mase Generators S.p.A.



mase generators spa

Via Tortona, 345 | 47522 - Cesena (FC) | Italy

Tel. +39 0547 354311

commercial@masegenerators.com

www.masegenerators.com

mase
GENERATORS
Believing in change.

CONTROL PANEL

_ CBU EVO IL4 device controls and drives the genset. The large display and control pushbuttons allow an easy use and monitoring:

- Manual start
- Voltage Vac
- Frequency Hz
- Hour meter
- Genset Battery voltage
- Low oil pressure alarm
- Engine preheating
- Engine high temperature alarm
- Alternator battery charger failure alarm
- Protection alarm for frequency and rpm
- Alarm history
- Maintenance warning
- General alarm outlet
- RUN outlet
- Ready outlet
- Programmable AUX outlet

_ Emergency stop button

_ Magneto-thermal protection

ENGINE

_ Easy maintenance access to the feeding and lubrication systems, the sea water pump and the air filter

_ Double vibration dumping system

_ Oil drain pump

SOUNDPROOF CABIN

_ Made of extremely light marine aluminum with very high resistance to external agents

Insulated poles kit (for metal hull boats), dry exhaust kit and keel cooling kit are available on request

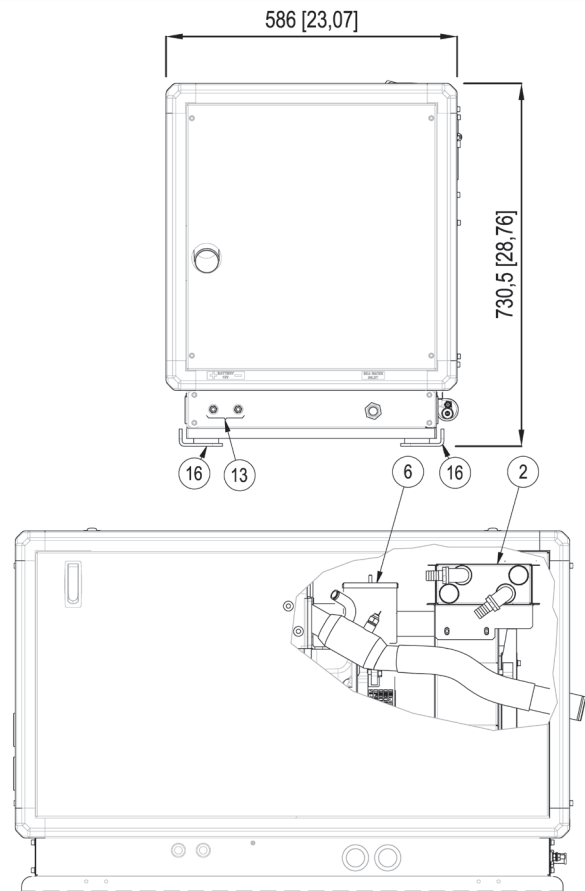
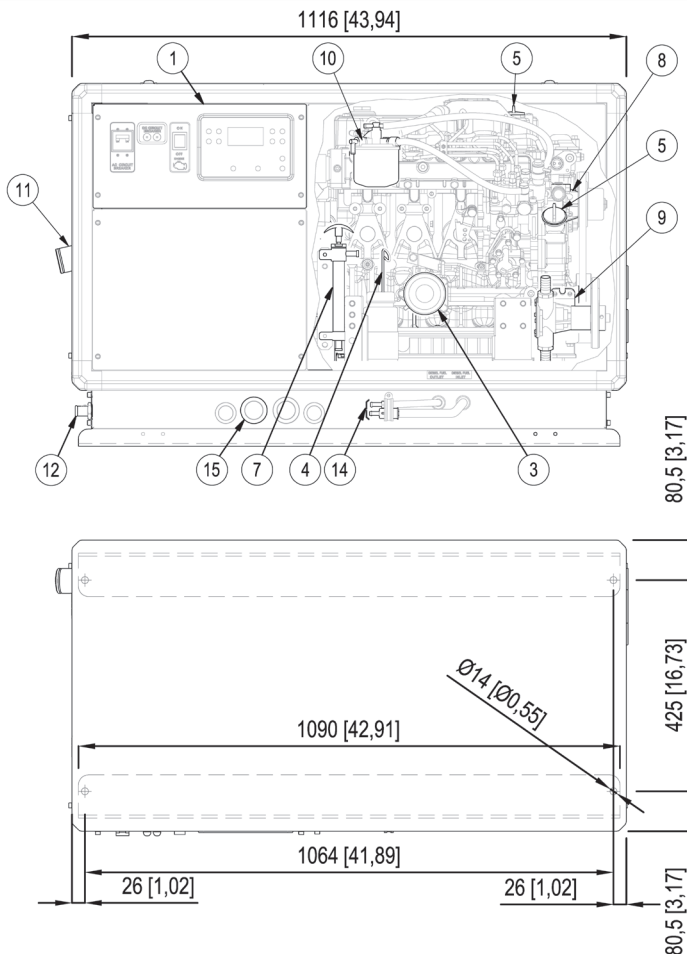

- | | | | |
|--------------------------|---------------------|--------------------------------|------------------------------------|
| 1. Control panel | 6. Air filter | 11. Exhaust manifold (d.50 mm) | 14. Fuel tank connections (d.8 mm) |
| 2. Air / water exchanger | 7. Oil drump pump | 12. Sea water intake (d.20 mm) | 15. Cables outlet |
| 3. Oil filter cartridge | 8. Fresh water pump | 13. Battery connections | 16. Genset fixing brackets |
| 4. Oil dipstick | 9. Sea water pump | | |
| 5. Engine oil filler | 10. Fuel filter | | |

IS 16

IS 19

mase
GENERATORS
Believing in change.

Output power 15.3 kW 50 Hz - 18.4 kW 60 Hz

| | 50 Hz | 60 Hz |
|--|---|----------------------------|
| AC alternator - | Synchronous, 4 poles, brushless, self-energized, with automatic voltage regulator (AVR) | |
| Cooling - | Air / Water (Intercooler W / A) | |
| Voltage - | 115 or 230 V | 120 or 240 V |
| Frequency - | 50 Hz | 60 Hz |
| Amps - | 133 or 66.5 A | 153.3 or 76.6 A |
| Max. Power - | 15.3 kW | 18.4 kW |
| Continuous power - | 13.7 kW | 16.7 kW |
| Power Factor - | cos ϕ 1 | |
| Insulating class - | H | |
| Voltage stability - | $\pm 2\%$ | |
| Frequency stability - | $\pm 5\%$ | |
| The power is referred to a sea water temperature up to 31°, an atmospheric pressure of 100 KPa and a humidity percentage of 30% | | |
| Model - | Yanmar 4TNV88 | |
| Type - | Diesel 4 stroke | |
| Cylinders - | nr 4 | |
| Cylinder block material - | Cast iron | |
| Bore - | 88 mm - 3.46 in | |
| Stroke - | 90 mm - 3.5 in | |
| Displacement - | 2190 cc - 133.6 CID | |
| Power - | 24.5 hp - 18.6 kWm | 29.4 hp - 21.92 kWm |
| RPM - | 1500 | 1800 |
| Compression ratio - | 19.1:1 | |
| Combustion system - | Direct injection | |
| Engine head material - | Cast iron | |
| Speed governor - | Centrifugal mechanical | |
| Lubrication system - | Forced | |
| Oil sump capacity with filter - | 7.4 l - 2.85 gl | |
| Engine stop system - | Solenoid valve | |
| Fuel pump - | Electric | |
| Max. fuel pump head - | 70 cm - 2.29 ft | |
| Fuel consumption | 5.6 l/h - 1.23 gl/h | 6.7 l/h - 1.47 gl/h |
| Air intake- | 1500 l/min - 396.25 gl/min | 1800 l/min - 475.50 gl/min |
| Starting battery - | 80 Ah - 12 V | |
| Battery charger - | 40 Ah - 12 V | |
| Starter motor - | 1.2 kW - 12 V | |
| Max. inclination - | 30° | |
| Water pump flow - | 25 l/min - 5.4 gl/min | 28 l/min - 6.1 gl/min |
| Sea water inlet pipe \varnothing - | 20 mm - 3/4" | |
| Exhaust pipe \varnothing - | 50 mm - 2" | |
| Input/Output fuel pipe \varnothing - | 8 mm - 5/16" | |
| Dimensions (L x W x H) - | 1116 x 586 x 730.5 mm - 44 x 23 x 29 in (with soundproof box) | |
| Weight - | 400 Kg - 948 lb (with soundproof box) | |
| Noise Level - | 50 dBA at 7 mt (23 ft) | |

Accessory

Code

ACCESSORIES ON REQUEST

| | |
|--|--------|
| 1. Remote control panel START/STOP with 20 mt cable for Comap | 037561 |
| 2. Remote control panel for Comap IL4 with 20mt cable | 039607 |
| 3. Mase exhaust kit: sea water lock, silencer, outlet D.50 | 04658 |
| · Vetus exhaust kit: sea water lock, silencer, outlet D.50 | 09935 |
| 4. Siphon break D.20 | 03796 |
| 5. Filtering kit: sea water inlet, sea water strainer, taps, fittings D.20 | 016422 |
| 6. Mase super silenced exhaust kit & exhaust gas separator D.50 | 010078 |
| 7. Centek 2" muffler | 71155 |
| · Vetus LP 50 S muffler | 71148 |
| 8. Centek 2" water/exhaust gas separator | 71156 |
| · Engine oil pressure and temperature sensor kit (Yanmar) | 011084 |
| · Vetus MP50 silencer | 71751 |



.1



.2



.3



.4

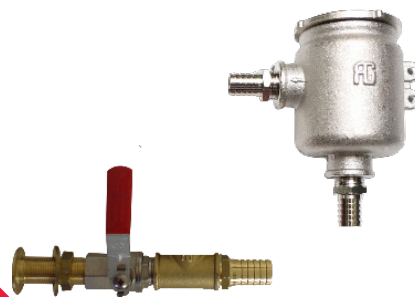

.5



.6



.7



.8